

## FIRE RATED CEILING FANS

**REVERSOMATIC** Model **EB** and **QB** - Fire Fighter Ceiling Fans with Integral Fire Radiation Damper and Grille, ceiling fan w/grille only.

- 115/1 Phase Thermally Protected Motors
- Plug Style Disconnect
- Fire Fighter Models UL Listed 3-4 hours
- Low Profile Design

1. Reversomatic Exhaust Fan
2. Firefighter Radiation Damper. Fits inside Fan Housing
3. Ceiling Grille, Fits over Firefighter Damper

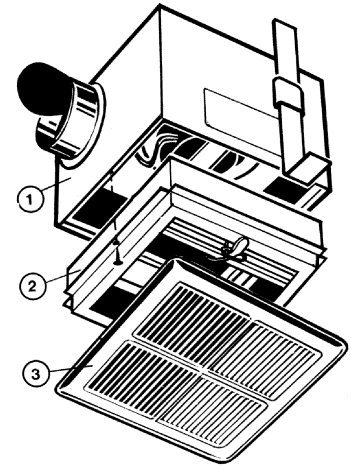

Model	CFM @ Listed Static Pressure							AMPS	SONES	Opening Size	"B" Dimension	Inlet Size $\varnothing$
	0.0	0.125	0.20	0.25	0.30	0.40	0.60					
FF-EB-60	65	59	58	57	55	48	36	0.9	2.5	8" x 9"	7"	3
FF-QB-100	115	98	92	82	73	47	-	0.6	2.5	9" x 9"	7 1/2"	4
FF-QB-150	158	149	143	134	126	102	-	0.9	4.3	9" x 9"	7 1/2"	5
FF-QB-200	201	182	174	166	158	172	145	1.4	5.3	9" x 9"	7 1/2"	5

**Note:**

1) For Speed Control and Other Accessories See Page 22.

The typical installation instruction shown below is in our opinion the best method of installation. Our suggested method of installation was derived from a combination of UL guidelines and Reversomatic's engineering department.

Fan Model	Price Each	FF Damper Model	Price Add FF Damper
EB-60	\$39	FF-50	\$65
QB-100	81	FF-100	69
QB-150	100	FF-100	69
QB-200	119	FF-100	69

