



Installation Instructions For 5500 Series Models (D)E4-M, (D)E4-ML, (D)E6-M, (D) E6-ML, (D)E6- LPC, (D)E8-M, (D)E8-ML, (D)E8-LPC Vertical & Horizontal Fire Dampers Static & Dynamic (D) Systems

Rated per UL555, UL File R6189

These Instructions Typify Both Horizontal And Vertical Installations Except As Noted,
And Apply Also To Masonry And Drywall Construction (see also Sheet GENII-2)

NOTES:

1. Minimum clearance between the wall/floor opening and the damper/sleeve assembly shall be 1/8" per foot of width and height, with a minimum of 1/4" for any size. Mounting angles shall overlap opening by 3/4" minimum on all sides up to 18" and 1" over 18".
2. The damper frame may be fastened to the sleeve using any of the following: 3/16" steel rivets, #14 sheet metal screws, #8 bolts and nuts or 1/2" tack welds spaced at a maximum of 8" center to center for 1-1/2 hour rated dampers and 6" maximum center to center for 3 hour rated dampers. A minimum of one fastener per side must be used. On multiple section damper assemblies of 4 or more sections that also have a 4 corner interior joint, all the interior joining must use 2 rows of fasteners.
3. Mounting retainers optional on both sides of the wall/floor opening and must be used on all 4 sides of the damper/sleeve assembly (exceptions noted). Minimum mounting retainer size is 1"x1"x18 gauge up to 18" and 1-1/2"x1-1/2"x18 gauge for vertical dampers up to 72" width or height. 1"x1"x16 gauge and 1-1/2"x1-1/2"x16 gauge for horizontal dampers. 2"x2"x18 gauge is used for larger dampers. Mounting retainers are to be attached to the damper/sleeve assembly using any of the following: 3/16" steel rivets, #14 sheet metal screws, #8 bolts and nuts or 1/2" tack welds spaced at a maximum of 12" center to center for 1-1/2 Hour rated dampers and 6" maximum center to center for 3 hour rated dampers. A minimum of one fastener per side must be used. Fasteners must not interfere with blade operation.
4. As per UL555, for rigid joints the thickness of the sleeve shall be a minimum of .053 inch for uncoated steel and .056 inch for coated steel with dimensions not exceeding 24 inches in height or 36 inches in width, and a minimum of .067 inch for uncoated and .070 for coated steel for larger size dampers.
5. EXCEPTION (to note #4): This requirement does not apply when one or more UL approved breakaway joints are used as the connection between the sleeve and ducts. In this case, the sleeve thickness shall not be less than that required by the Standard for the Installation of Air-Conditioning and Ventilating Systems, NFPA 90A. For Ductmate Type connections, a modified 4 bolt system may be used. See Sheet GENII-3 for details.

Instructions for Installations WITH Sleeves

No additional sleeve is required when the damper is installed in duct of 20 gauge or less and a UL approved breakaway connection is used.

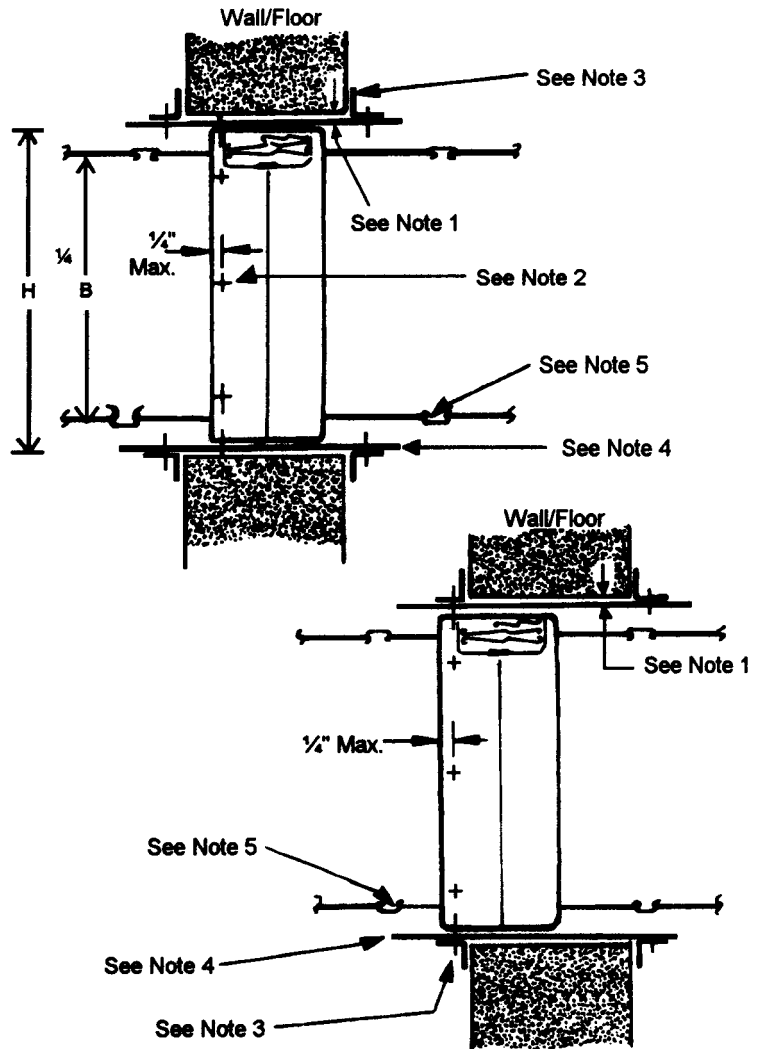

REPRESENTED BY

MANUFACTURED BY
PERFECT AIR CONTROL, INC.
 1310 N. HERCULES AVE. CLEARWATER, FL 33765
 CUSTOMER SERVICE (800) 437-6653 * ORDER ENTRY FAX (727) 431-6074
 www.prefco-hvac.com



Installation Instructions For 5500 Series Models (D)E4-M, (D)E4-ML, (D)E6-M, (D)E6-ML, (D)E6-LPC, (D)E8-M, (D)E8-ML, (D)E8-LPC Vertical & Horizontal Fire Dampers Static & Dynamic (D) Systems

Rated per UL555, UL File R6189

These Instructions Typify Both Horizontal And Vertical Installations Except As Noted, And Apply Also To Masonry And Drywall Construction (see also Sheet GENII-2)

Instructions for Installations WITHOUT Sleeves

Any combination of mounting pieces shown below (Angles, Flats, Dog Lugs (E6 & E8 only), EZ Mount Retaining Angles or "Z" pieces) may be used provided the plane of the closed blades remains within the plane of the wall.

MOUNTING DETAILS - Pieces Cut as Shown

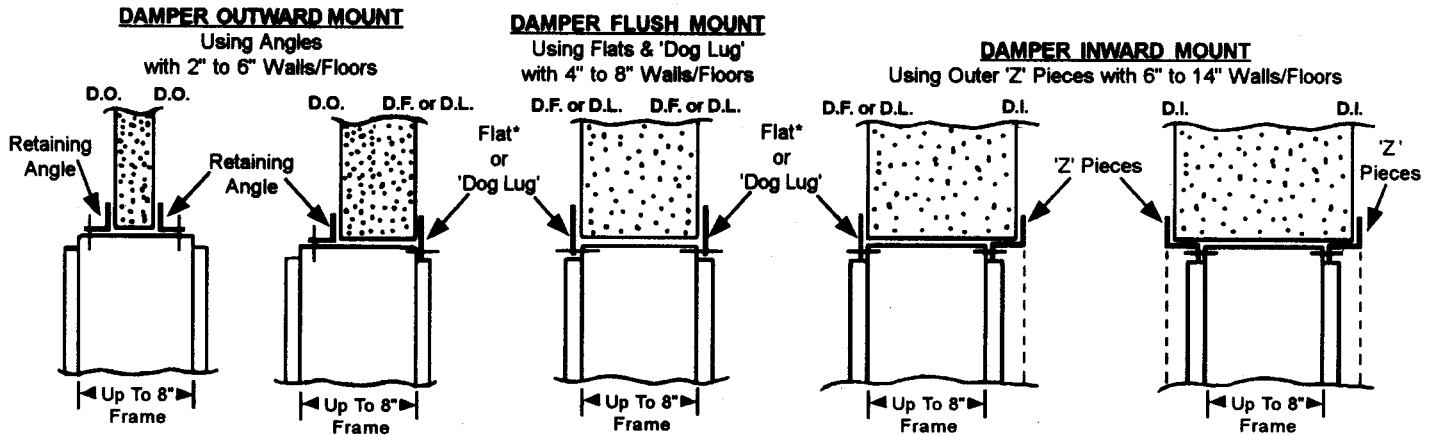

Any Combination Of DL, DF, DI & DO Is Permitted (Factory or Field Supplied)

*DO - EZ MOUNT RETAINING ANGLES

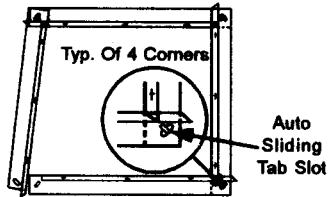

- Retaining Angle With Sliding Corners For Tight Fit (See Supplemental Info Sheet EZAngle)
- May be used in lieu of conventional retaining angles on all Fire & Leakage Rated Dampers. Max. 96" x 48"

DF - FLATS

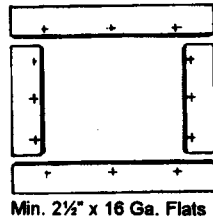

Min. 2 1/2" x 16 Ga. Flats

DL - 'DOG LUG' INSTALLATION

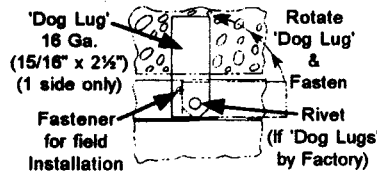

'Dog Lug' 16 Ga. (15/16" x 2 1/2") (1 side only)
Rotate 'Dog Lug' & Fasten
Fastener for field installation
Rivet (if 'Dog Lugs' by Factory)

DI - Z'S

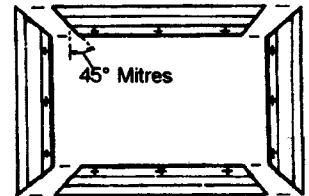

Min. 1" x 1/4" x 1" x 14 Ga. for 6" to 9-7/8" Walls/Floors
Min. 1 1/2" Outer Flange for 10" to 12" Walls/Floors

TYPICAL MULLION ARRANGEMENT

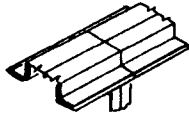

DETAIL VIEW OF 'DOG LUGS'



NOTES:

1. Minimum clearance between the wall/floor opening and the damper/sleeve assembly shall be 1/8" per foot of width and height, with a minimum of 1/4" for any size. Mounting angles shall overlap opening by 3/4" minimum on all sides up to 18" and 1" over 18"
2. Mounting retainers optional on both sides of the wall/floor opening and must be used on all 4 sides of the damper/sleeve assembly (exceptions noted). Minimum mounting retainer size is 1"x1"x18 gauge up to 18" and 1-1/2"x1-1/2"x18 gauge for vertical dampers up to 72" width or height. 1"x1"x16 gauge and 1-1/2"x1-1/2"x16 gauge for horizontal dampers. 2"x2"x18 gauge is used for larger dampers. Mounting retainers are to be attached to the damper/sleeve assembly using any of the following: 3/16" steel rivets, #14 sheet metal screws, #8 bolts and nuts or 1/2" tack welds spaced at a maximum of 12" center to center for 1-1/2 Hour rated dampers and 6" maximum center to center for 3 hour rated dampers. A minimum of one fastener per side must be used. Fasteners must not interfere with blade operation.
3. Factory mounted Dog Lugs (6"c-c max.) are optional to replace flats, angles or Z's in dual angle installations. Dog Lugs must be on the bottom side of horizontal installations.
4. No sleeve is required when the damper is connected to a duct of 20 gauge or less and when a slip connection is used.
5. When the damper is installed without a sleeve, a slip joint is used on the "M" models. The ML is supplied with factory supplied slip joints.
6. Openings between the damper assembly and the wall/floor opening must be covered by the perimeter mounting pieces, to prevent see-through openings.
7. Mitre cut or straight cut corners are acceptable
8. For multiple section assembly, also refer to sheet 5500II-10